

TEMCO-Riley D-16A

Riley '55

The D-16A was a continued development of the D-16, introduced two years prior. With important items such as constant speed, fully feathering propellers now developed, the goal was set for the D-16A, or Riley '55 to meet the performance numbers originally quoted for its older brother.

Lycoming was asked to develop a higher horsepower engine, resulting in the 170hp O-340-A1A. Fuel tanks were increased from two to five, which removed the under seat fuel tank and improved safety. Access to the rear cargo compartment was now made through a separate door on the rear left hand fuselage - a major improvement over other Navion models. The cockpit was equipped with the latest in avionics, heavily padded leather seats and plush appointments. Externally all D-16As left TEMCO's Greenville Texas plant with a standard paint scheme - a first for any Twin Navion.

As new designs from Cessna, Piper and Beech arrived on the market, sales of the Twin Navion panned out, production ceased in 1957 at serial number TTN-90.

Several D-16s in both the TN and TTN serial number ranges returned to TEMCO (before and after production ceased) for upgrades to D-16A standard.

COLOR NOTES:

D-16AS WERE THE ONLY TWIN NAVIONS TO FEATURE A FACTORY STANDARD COLOR SCHEME.

OVERALL AIRFRAME: WHITE

ACCENT TRIM:
 RED
 DARK BLUE
 LIGHT BLUE
 TEAL BLUE/GREEN

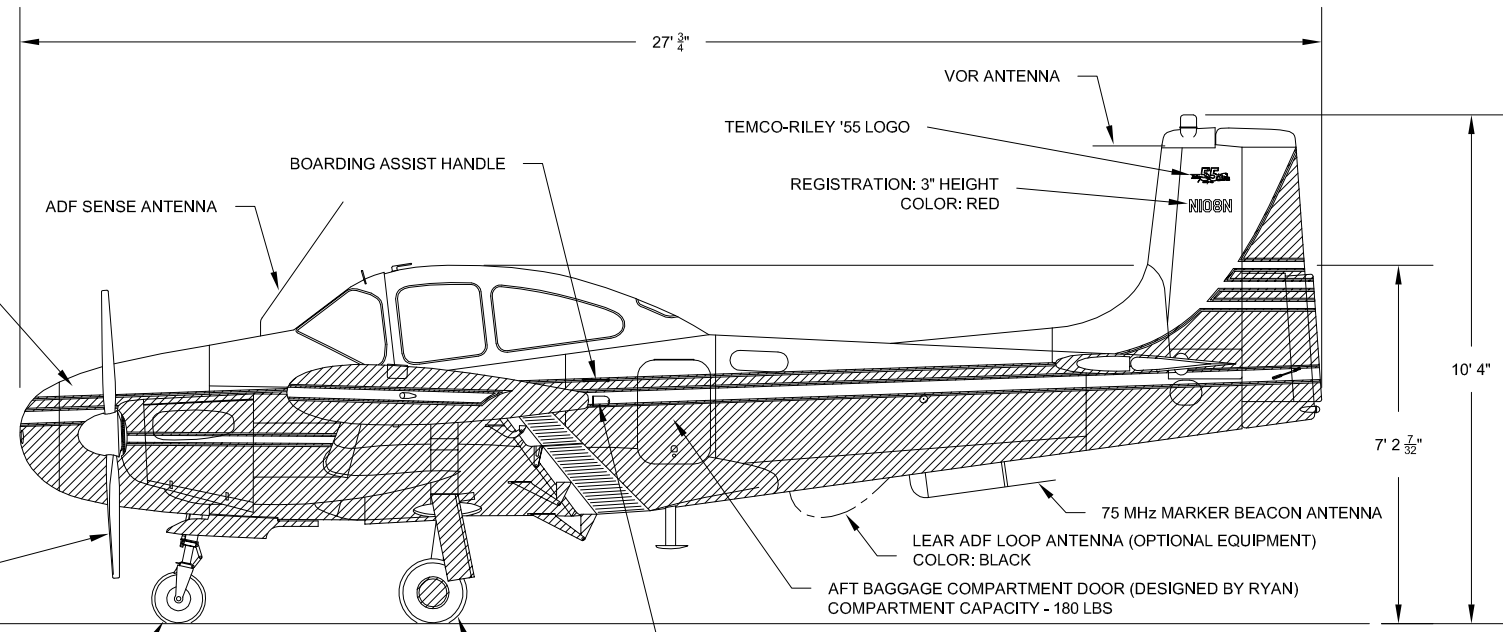
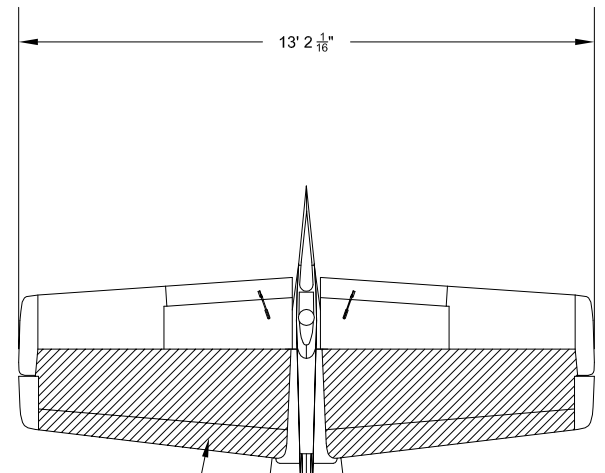

HORIZONTAL STABILIZER
 ANGLE OF INCIDENCE CHANGE

FORWARD BAGGAGE
 COMPARTMENT
 CAPACITY - 100 LBS

72.0" TO 70.0" DIAMETER
 HARTZELL CONSTANT SPEED
 PROPELLER MODEL HC 82xG-2 HUB
 WITH (METAL) BLADE MODEL 8433-12

VOR ANTENNA
 TEMCO-RILEY '55 LOGO
 REGISTRATION: 3" HEIGHT
 COLOR: RED

75 MHz MARKER BEACON ANTENNA
 LEAR ADF LOOP ANTENNA (OPTIONAL EQUIPMENT)
 COLOR: BLACK

AFT BAGGAGE COMPARTMENT DOOR (DESIGNED BY RYAN)
 COMPARTMENT CAPACITY - 180 LBS

6.00x6 NOSE WHEEL
 (STEERABLE)

7.00x8 MAIN WHEEL

GROUND POWER PLUG ACCESS

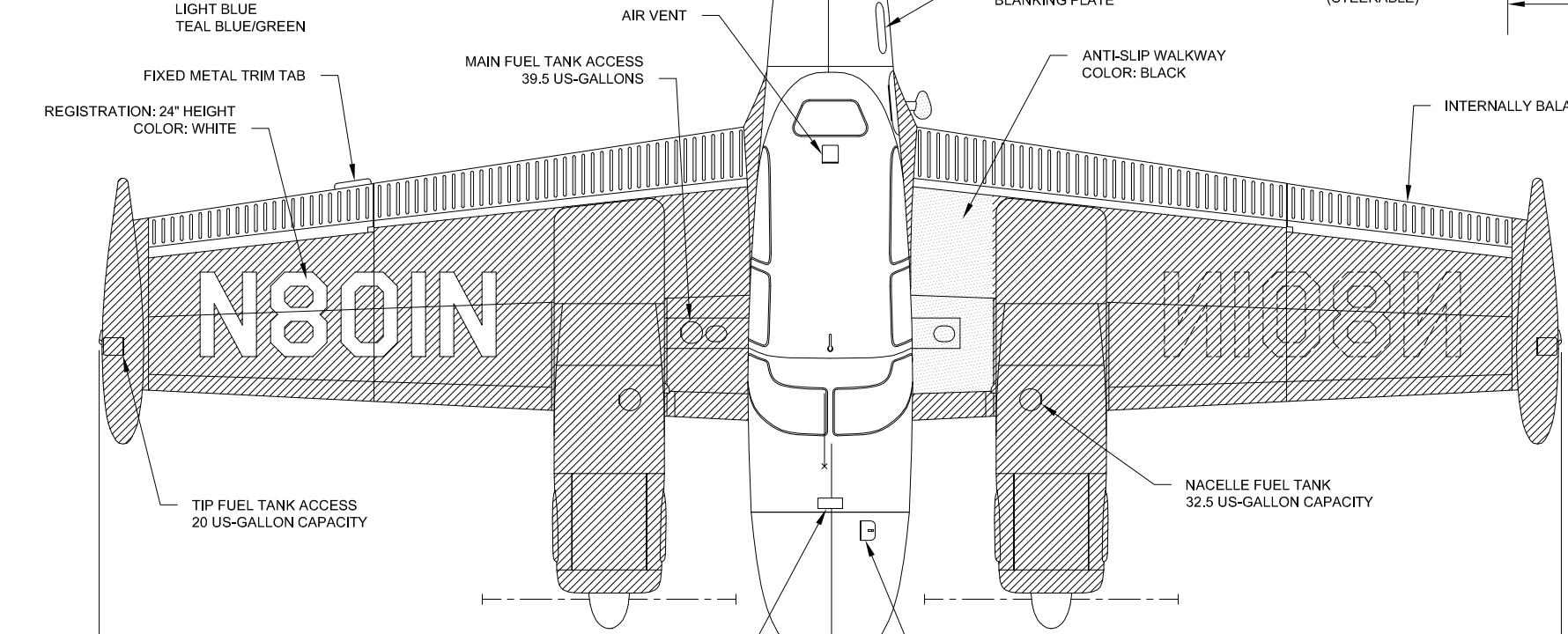

MAIN FUEL TANK ACCESS
 39.5 US-GALLONS

FLARE COMPARTMENT
 BLANKING PLATE

ANTI-SLIP WALKWAY
 COLOR: BLACK

INTERNALLY BALANCED AILERONS

CANOPY FULLY OPEN
 24" OF MOVEMENT

FIXED METAL TRIM TAB

REGISTRATION: 24" HEIGHT
 COLOR: WHITE

TIP FUEL TANK ACCESS
 20 US-GALLON CAPACITY

NACELLE FUEL TANK
 32.5 US-GALLON CAPACITY

FORWARD BAGGAGE
 COMPARTMENT DOOR
 FULLY OPEN

LANDING LIGHT
 AND TAXI LIGHT

HEATER AIR INLET

ROTATING BEACON
 TAXI LIGHT (LOW INTENSITY) BOTH LAMPS
 LANDING LIGHT (HIGH INTENSITY) PORT LAMP

SOUTH WIND HEATER EXHAUST

CABIN AIR VENT

HYDRAULIC RESERVOIR
 ACCESS

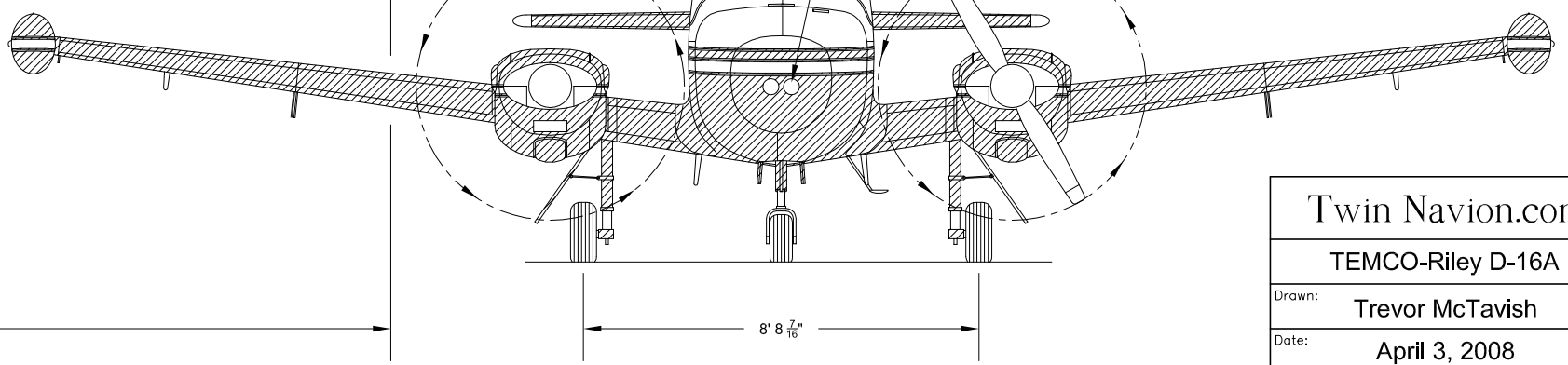
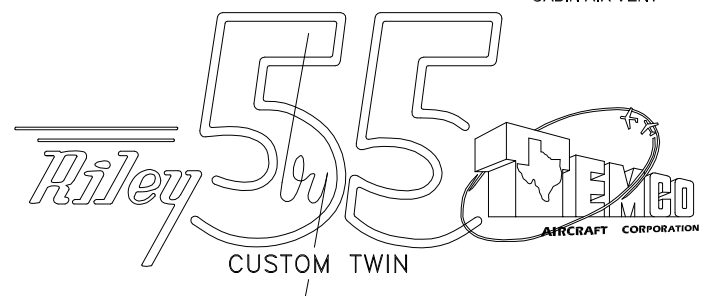

Twin Navion.com	
TEMCO-Riley D-16A	
Drawn:	Trevor McTavish
Date:	April 3, 2008
Scale:	1/48
Sheet:	1/1