

North American NAvion and Ryan Aeronautical Company Navion A Exterior Paint and Interior Furnishings

1946 - North American Aviation

Basic: Overall unpainted metal with either Dark Red or Green glare-shield and stripe. Registrations in black.

1947 - North American Aviation

Basic: Overall unpainted metal with either Dark Red or Green glare-shield and stripe. Registrations in black.

1947/1948 - Ryan Aeronautical Company

Basic: Overall Riviera Blue, Lucerne Green or Royal Maroon with Ryan stripe, registrations and logos in Italian Cream.

1949 - Ryan Aeronautical Company

Basic: Overall Chevron Blue, Lucerne Green or Tampico Red with Ryan stripe, registrations and logos in Italian Cream.
Overall Italian Cream with Ryan stripe, registrations and logos in Tampico Red.

Optional: Italian Cream upper fuselage, remainder in either Riviera Blue, Lucerne Green or Royal Maroon. No striping or logos applied.

Custom: Customer specified color schemes were available upon demand.

1950 - Ryan Aeronautical Company

Basic: Overall Chevron Blue, Lucerne Green or Tampico Red with Ryan stripe, registrations and logos in Italian Cream.
Overall Italian Cream, Ryan stripe, registrations and logos in Tampico Red.

1951 - Ryan Aeronautical Company

Utility 205: Overall Desert Tan with Ryan stripe, registrations and logos in Red.

De Luxe 205: Overall Ceramic Red, Gala Green or Coastal Blue with Ryan stripe, registrations and logos in White.

NOTE: ON ALL DRAWINGS, THE UNDERWING REGISTRATION (24" HEIGHT) HAS BEEN OMITTED FOR CLARITY,

Ryan Navion

Ryan Aeronautical Company - San Diego, California

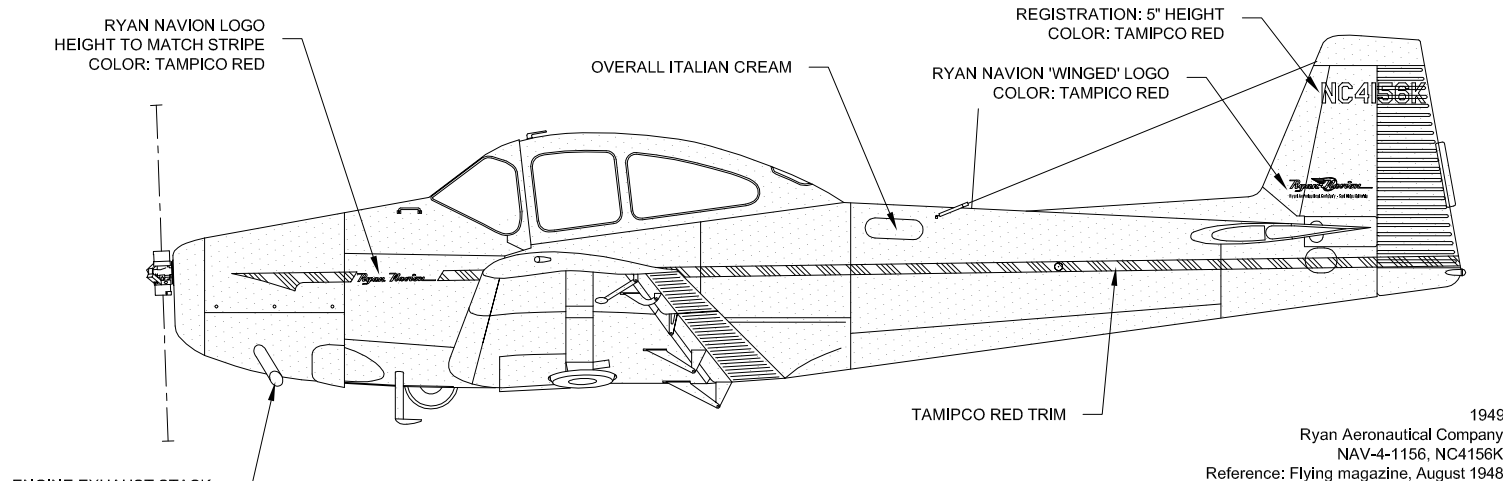

1949
Ryan Aeronautical Company
NAV-4-1156, NC4156K
Reference: Flying magazine, August 1948

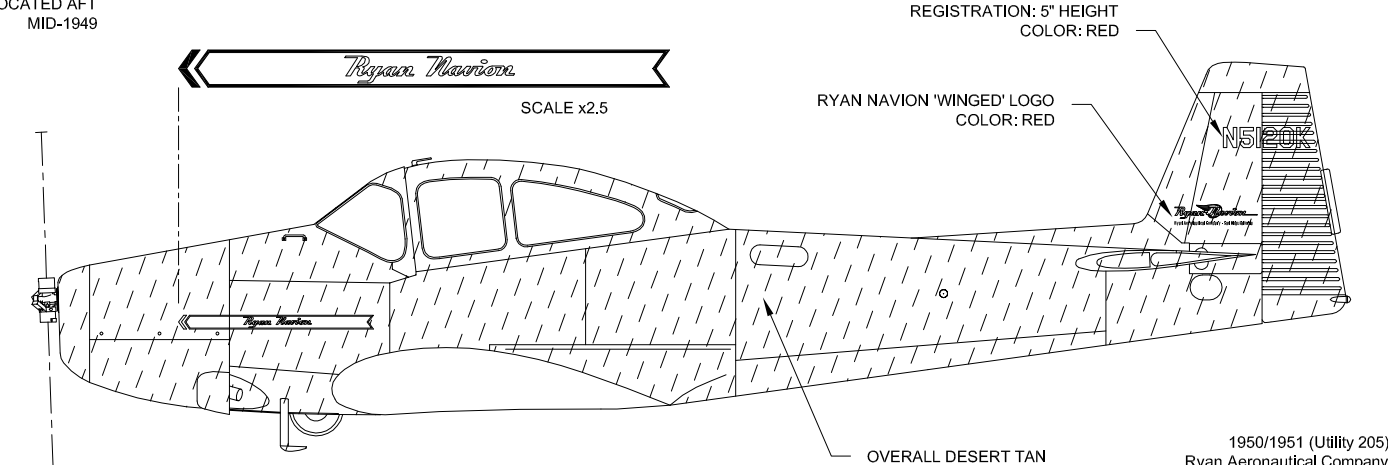

1950/1951 (Utility 205)
Ryan Aeronautical Company
NAV-4-2020, N5120K
Reference: Ryan sales brochure

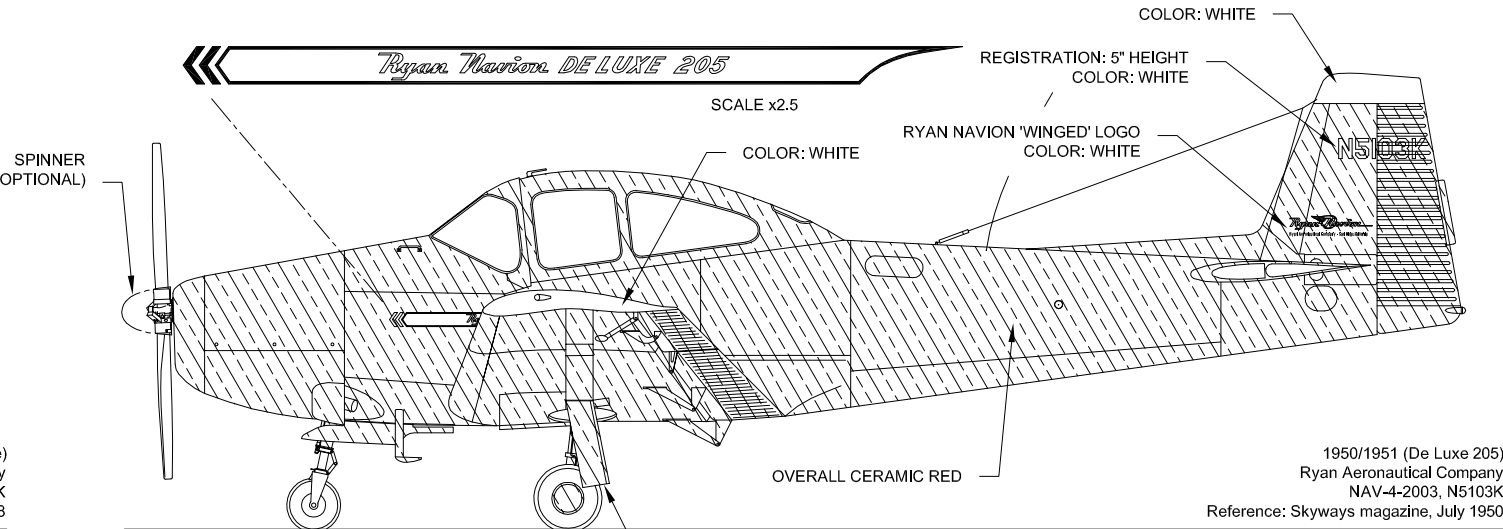

1950/1951 (De Luxe 205)
Ryan Aeronautical Company
NAV-4-2003, N5103K
Reference: Skyways magazine, July 1950

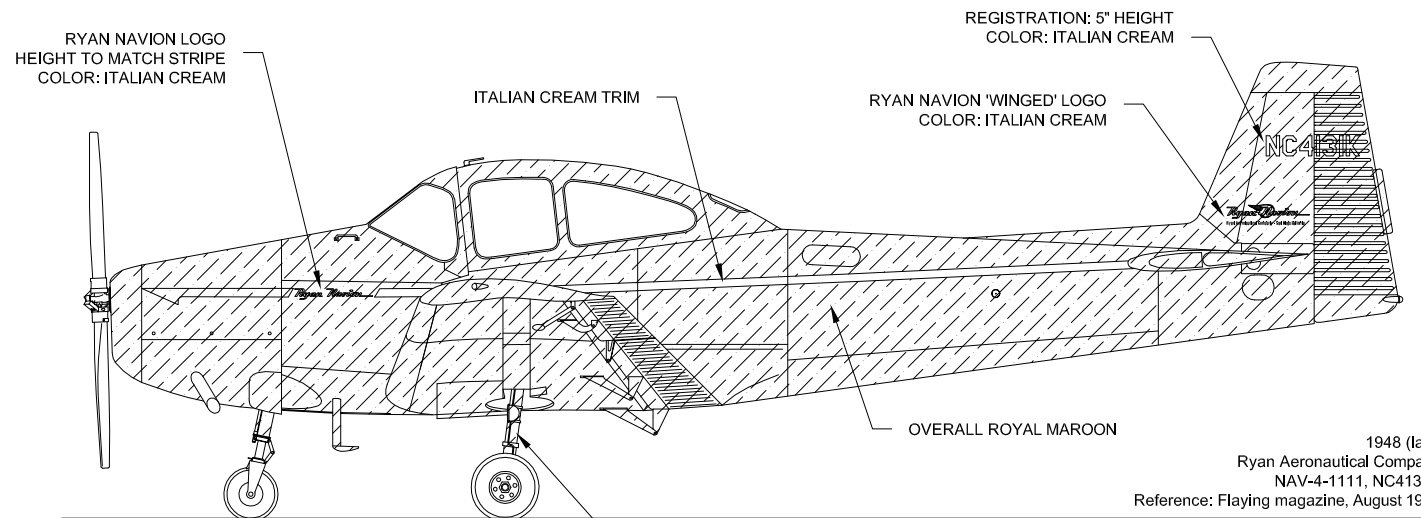

1948 (late)
Ryan Aeronautical Company
NAV-4-1111, NC4131K
Reference: Flying magazine, August 1948



Twin Navion.com	
NAA NAvion / Ryan Navion A	
Drawn:	Trevor McTavish
Date:	October 1, 2007
Scale:	1/48
Sheet:	2/2